

EUROSYSTEM[®] STD & ALD

Aluminium and **steel** hollow profile
for overhead handling system
with loads of 60 to 2,000 kg



EUROSYSTEM *STD*

Overhead handling system in **steel profile** for loads of up to 2,000 kg

> Steel profiles

Load capacity of up to 2,000 kg according to profile. The basic component of the overhead handling system is a cold-formed high strength hollow steel profile that provides an extremely uniform surface. The closed structure of the profile makes it possible to keep the inside of the runway clean.

There are 5 sizes in the range of profiles that can be selected depending on the load capacity and the distance between the suspension points:

STD II-H-R is the strengthened version of the STD II profile with integrated power supply (5 pole conductor).

STD II-H is the strengthened version of the STD II profile for loads of up to 3,200 kg.

STD II-R is the STD II profile version with integrated power supply (5 pole conductor).

STD II for loads of up to 2,000 kg.

STD II-L for loads of up to 1,000 kg.

STD I for loads of up to 500 kg.

STD 100 for loads of up to 125 kg.

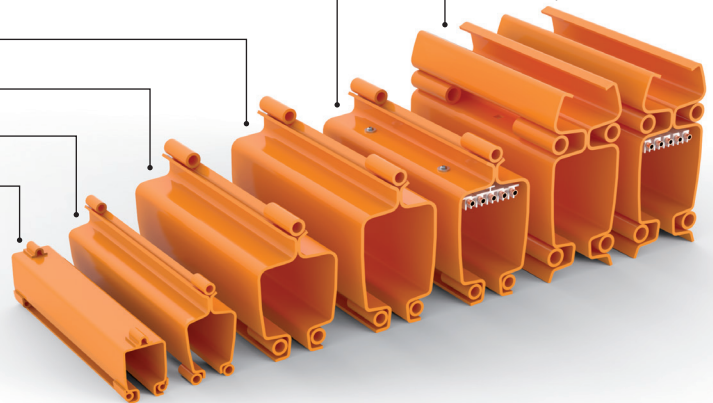

> Numerous possibilities

This range of profiles associated with other components like suspensions, manual or electric travelling trolleys and cross travel trolleys enable many lifting solutions to be implemented.

- > Monorail tracks.
- > Runways.
- > Single girder overhead cranes.
- > Double-beam overhead cranes.
- > Telescopic beams.
- > Single or complete circuit systems with change of travel direction by switch or multi-directional turntable.

> Undeniable advantages

- > The loads are easy to handle, thanks to an excellent rolling coefficient.
- > Numerous types of fixation, adaptable to any structure.
- > Installations are pleasing to the eye.
- > The load on the bearing structure is kept to a minimum through the pendular design of the system.
- > Monorail tracks, runways and circuits easily extended thanks to the system's modularity.
- > Maintenance is practically zero.
- > Great flexibility.
- > Minimum loss of headroom
- > Installation and fixation by simple bolting.

EUROSYSTEM *ALD*

Aluminium hollow profile for overhead handling system with loads of 60 to 2,000 kg

> Profiles

Load capacity of up to 2,000 kg according to profile. The basic component of the overhead handling system is a cold-formed high strength hollow steel profile that provides an extremely uniform surface. The closed structure of the profile makes it possible to keep the inside of the runway clean.

There are 4 sizes in the range of profiles (2 of them available with integrated power supply), that can be selected depending on the load capacity and the distance between the suspension points:

A 22 R is the strengthened version of the ALD A22 profile with integrated power supply (5 pole conductor).

A 22 for loads of up to 2,000 kg.

A 18 R is the strengthened version of the ALD A18 profile with integrated power supply (5 pole conductor).

A 18 for loads of up to 1,000 kg.

A 16 for loads of up to 500 kg.

A 12 for loads of up to 500 kg.

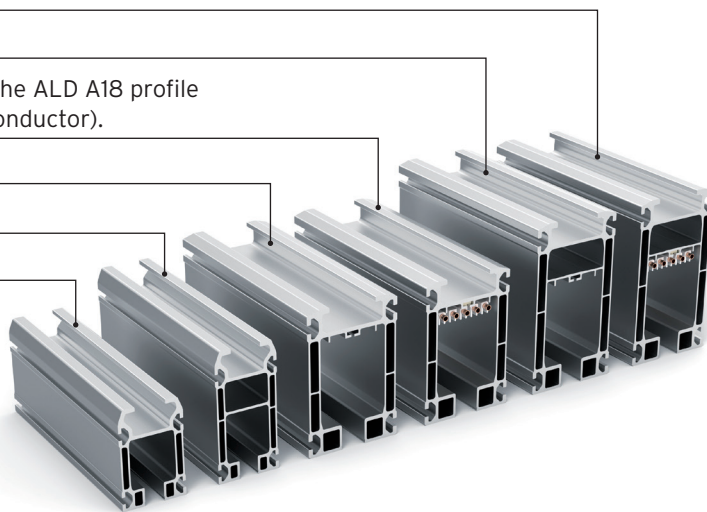

> Numerous possibilities

This range of profiles associated with other components like suspensions, manual or electric travelling trolleys and cross travel trolleys enable many lifting solutions to be implemented.

- > Monorail tracks.
- > Runways.
- > Single girder overhead cranes.
- > Double-beam overhead cranes.
- > Telescopic beams.

> Undeniable advantages

Eurosystem ALD Aluminium represents a new generation of hollow profile handling systems. This innovative solution presents the combined advantages of conventional steel and aluminium hollow profile. Steel and aluminium profile may be combined. Similar advantages coming from Steel with benefits from Aluminium.

- > **ERGONOMIC.** Light rails means users can very easily and effortlessly handle heavy and cumbersome loads.
- > **ACCURATE.** Accuracy is ensured through high quality manufacture and smooth movements.
- > **ANTICORROSION.** The aluminium profiles are externally and internally anodised.
- > **SAFETY.** The beam is guaranteed without welding.
- > **TECHNOLOGICAL.** The beam is the result of the latest innovations in cold extrusion and structure optimisation.
- > **PRACTICAL.** The beam is compatible with all ITEM standard accessories.
- > **LASTING.** Strong resistancy to wear and tear is the result of anodisation and the roller materials.
- > **SILENCE.** Operates silently due to the precise manufacture of the movement surface.



EUROSYSTEM *STD & ALD*

Overhead handling system in **steel** and **alu profile** for loads of up to 2,000 kg

Suspended or encasted single-beam crane, rigid or articulated structure

Practical solution designed for handling needs in large facilities. Reduced approach distances and the compactness of EUROSYSTEM STD and ALD components enable optimization of working space. This characteristic enables access for handling to non-rectangular spaces and to areas inaccessible to conventional systems. Suspended on trolleys, the girder travels along the length of the runway profiles (driven manually or electrically). For longer spans, rigid connections enable optimize beam travel. EUROSYSTEM STD and ALD profiles are also used as runways and can be attached to the ceiling with an appropriate suspension system.

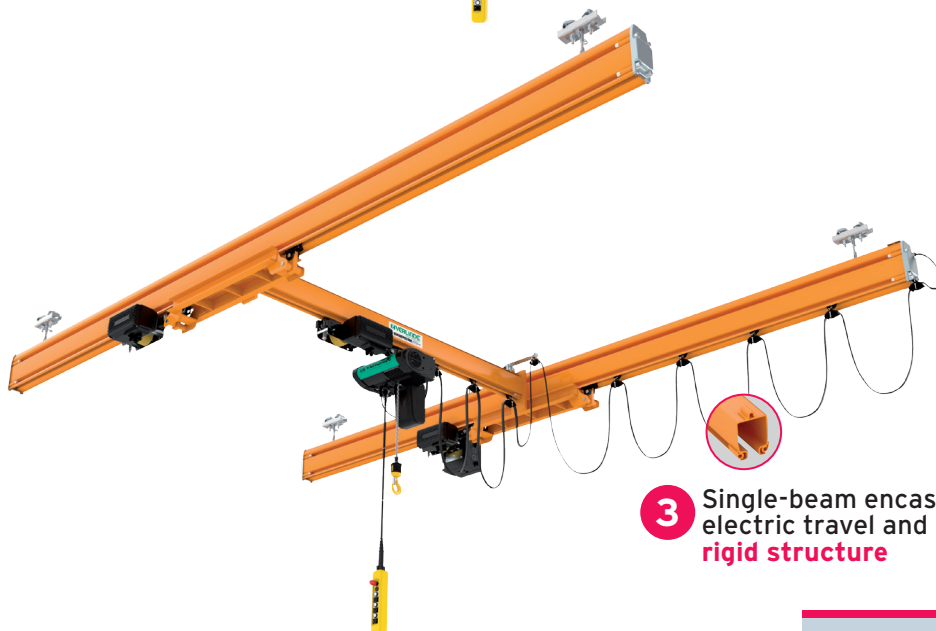
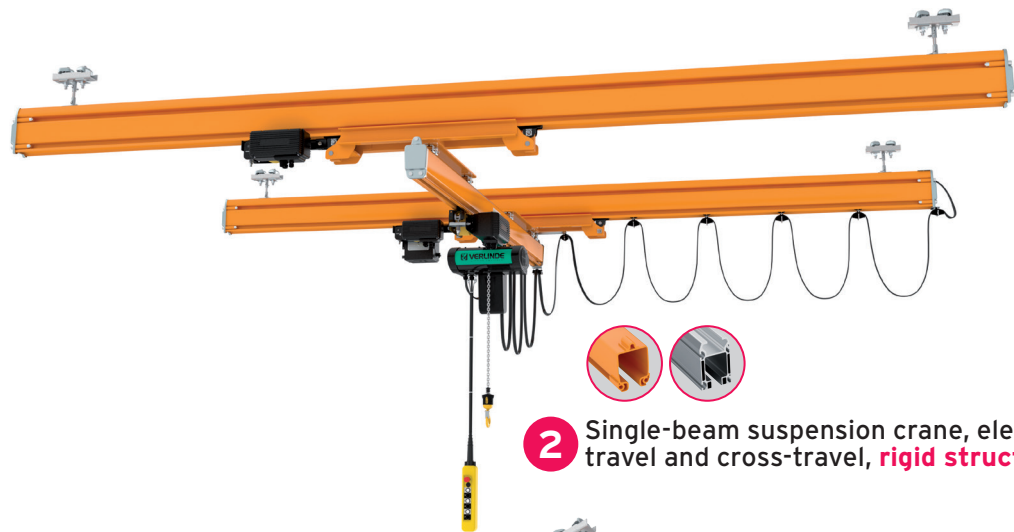
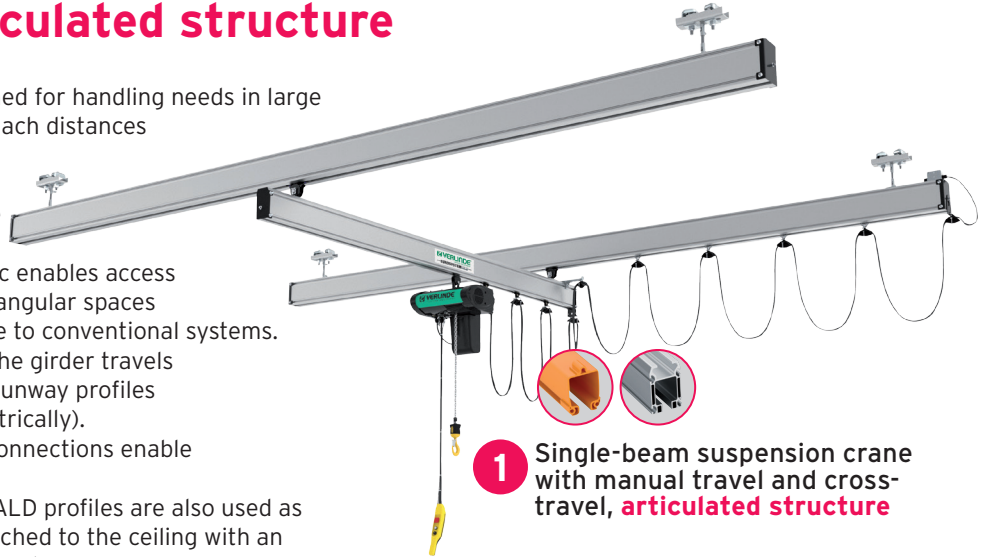

Double-beam suspended or encasted crane, rigid or articulated structure

For much heavier loads over wide spans or for frequent manipulation cycles, the EUROSISTEM STD and ALD double-beam crane will be ideal for your lifting and handling requirements.

The design of the encasted hoist-bearing trolley travelling between beams enables a minimum loss of headroom.

The crane also enjoys great travel flexibility through the use of trolleys with synthetic rollers on ball bearings inside the profiles. Travel is achieved either by pushing the load or through the use of a motorized trolley (recommended for heavy loads and long spans).

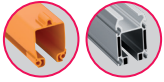
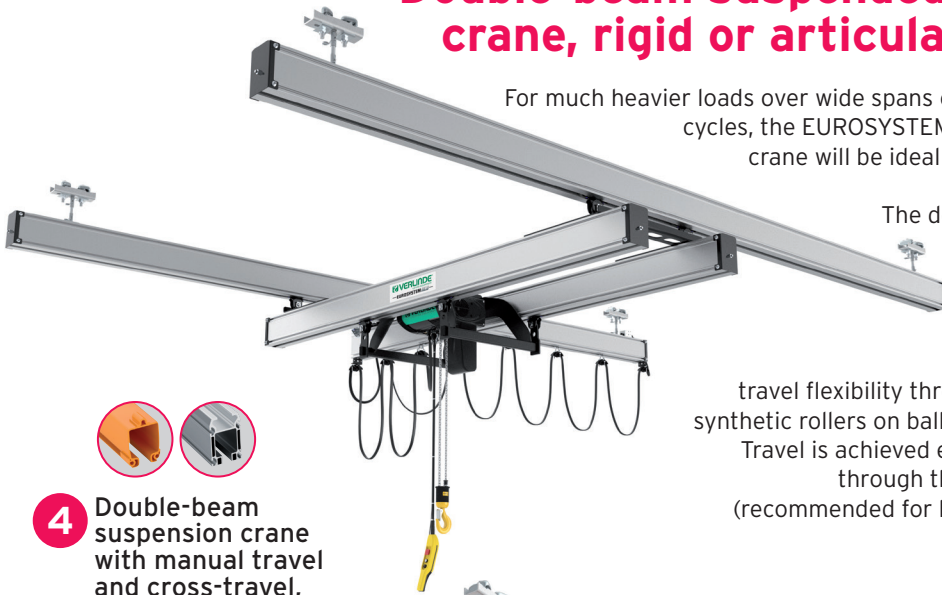

4 Double-beam suspension crane with manual travel and cross-travel, **articulated structure**

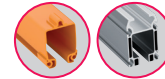
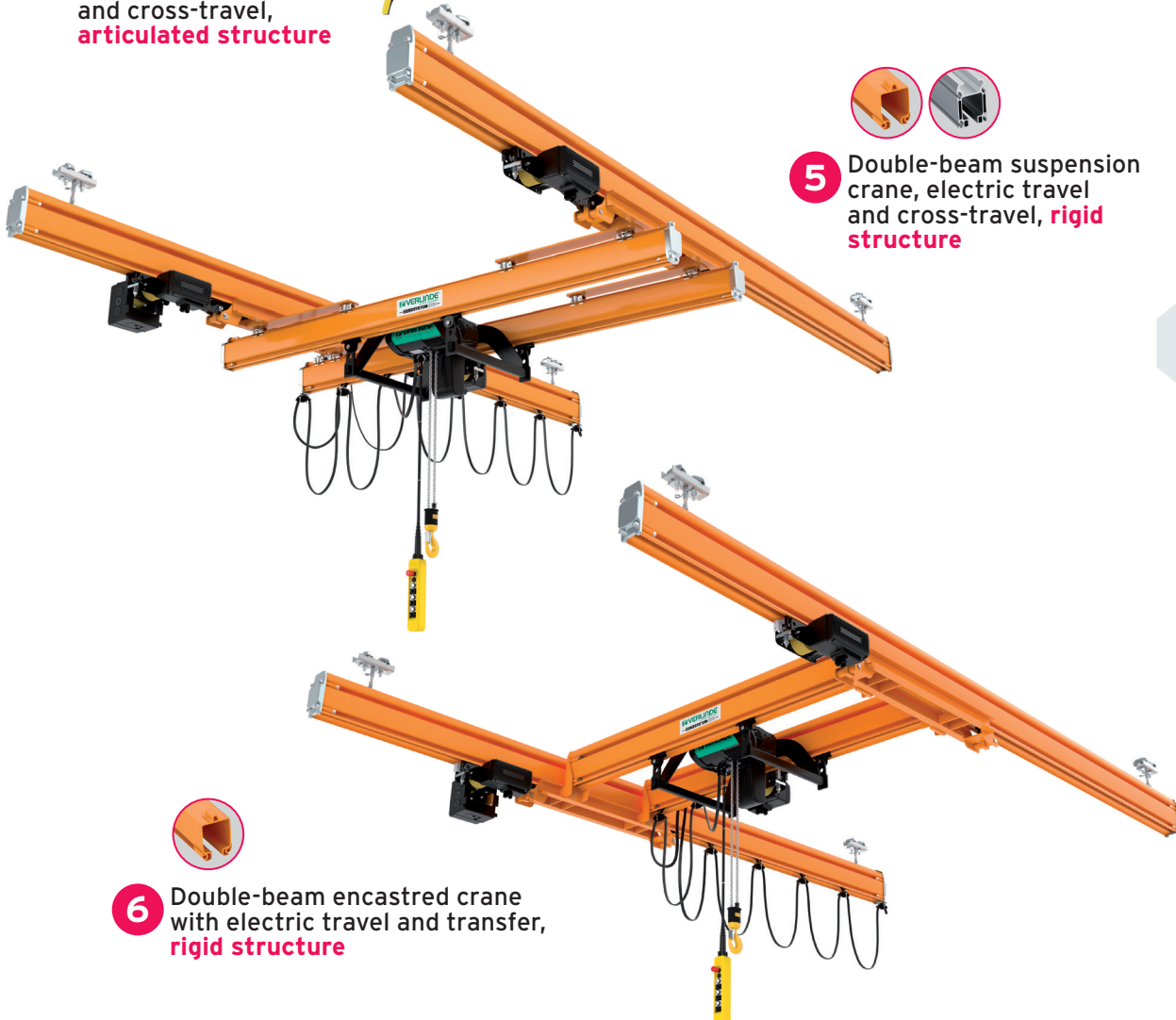

5 Double-beam suspension crane, electric travel and cross-travel, **rigid structure**



6 Double-beam encasted crane with electric travel and transfer, **rigid structure**

Type of constructions:	Item	EUROSISTEM STD	EUROSISTEM ALD
Single beam suspended crane with articulated structure	1	●	●
Single beam suspended crane with rigid structure	2	●	●
Single beam encasted crane with rigid structure	3	●	
Double beam suspended crane with articulated structure	4	●	●
Double beam suspended crane with rigid structure	5	●	●
Double beam encasted crane with rigid structure	6	●	

EUROSYSTEM STD & ALD

Overhead handling system in **steel** and **alu profile** for loads of up to 2,000 kg

1

Cover plates

They are located at ends and are designed to:

- > To prevent any twisting of the hollow profile.
- > To keep manual or motorized trolleys securely on the roller paths at the ends of tracks.
- > To keep the inside of profiles clean and dust-free.

2

Trolleys

Any system can be equipped with trolleys in order to ensure travel and transfer movement of hoist and suspension crane.

The range of available stand-alone trolleys is very comprehensive and will meet all your requirements:

- > Single, double or articulated manual trolleys.
- > Simple, double or articulated motorized trolleys.

The contact surface with the internal part of the profile has been reduced to obtain a remarkable rolling coefficient: thus ensuring noiseless and effortless movement. The trolley rollers are synthetic for reasons of minimum routine

maintenance and excellent resistance to wear. Furthermore, they have a shock-dampening effect and remain noiseless, even at high travel speeds.

Through the modularity of the EUROSYSTEM STD and ALD overhead handling system, a manual trolley can be replaced at a later date by an electric trolley.

The electric trolleys are fitted with solid rubber drive wheels to obtain high torque drive and a low operating sound level.

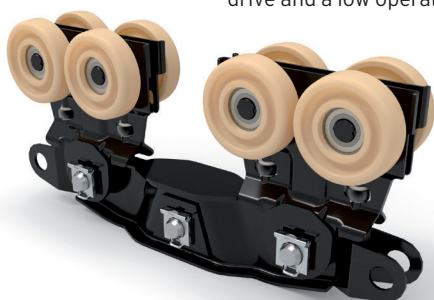
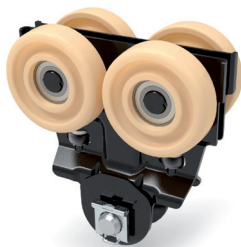

3

Hollow profiles assembly

The assembly of the profiles is done with connection bolts and connection parts with adapted locating features.

4

Threaded rods

Threaded rods are inserted on suspension systems to facilitate height adjustment.

5

Profiles

There are 5 sizes in the range of profiles that can be selected depending on the load capacity and the distance between the suspension points. All the profiles receive an anti-corrosion protective treatment and then a coat of finishing paint (cataphoresis process) or are galvanized (option).

8

3

1

7

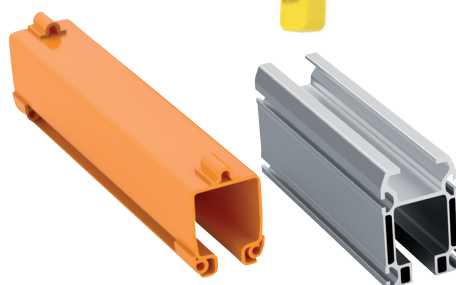

6

Manual, electric or pneumatic lifting units



Hand chain hoist **VHR** for loads of 250 to 5,000 kg: the chain sprocket and gears are machined to provide smoother, more efficient operations and smoother lifting manoeuvres. VHR's compact design offers safety together with reduced weight. This hoist is ideal for construction, assembly and maintenance applications.

Lifting functions are fulfilled by **EUROCHAIN VR** hoists with a wide range of load capacities and lifting speeds.

- These hoists can be equipped with either a manual or an electric trolley for horizontal movement.
- > Load capacity from 63 à 2,000 kg.
- > Lifting height from 3 meters (standard) and up to 30 m.
- > Two lifting speeds.
- > A number of optional features are available for these hoists (remote control system, hook version and stainless steel chain, manipulator on hook, speed variation,...).



5

EQUIBLOC AIR is delivered with the following standard equipment:

- > Lift and lowering control circuit.
- > 6 m of cable with hook.
- > Spiral flexible control conduit,
- > Valve-box type control interface.
- > Proportional lift and lowering control unit with load balancing system.
- > With safety valve to keep pressure in tank if the control tube is cut.

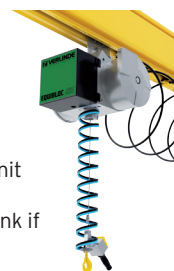

2

4

7

Power feed systems

Two types of power feed systems are available:

- > As exterior flat cables to the profile (daisy chain) with specific cable bearing trolleys for hollow profiles
- > Power feed integrated in profile (5 pole conductor).

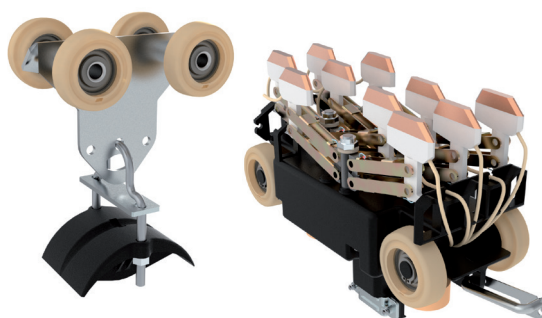

8

Suspensions

They allow fitting the light crane system to the support structure. Several types of suspensions are available according to the type of profile used, and the type of structure supporting the system. Thanks to their design (self-locking parts, articulated structure, easy adjustments, etc.). EUROSYSTEM STD and ALD suspensions allow greater flexibility when being installed, prevent internal pressure and balance any possible irregularities of the support structure. An antifriction system of synthetic material is included on the flexible coupling to reduce the noise level and reduce routine maintenance of joints to a minimum.

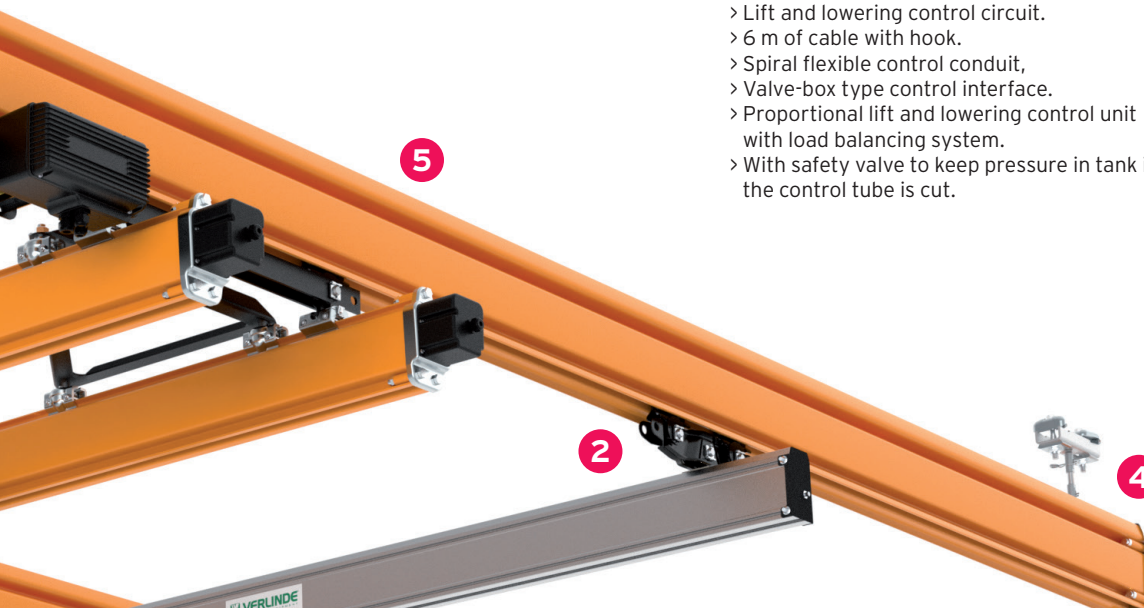

VERLINDE is:

- The leading French manufacturer and exporter of lifting and handling equipment.
- A comprehensive range of 30 groups of lifting equipment from 60 to 250,000 kg.
- ISO 9001 Quality control certified and ISO 14001 Environmental Management Systems.

In France:

A sales network and after sales service points, EUROPONT travelling crane construction plants and a distributor network.

Abroad:

A customer service in more than 92 countries.

References

Metallurgy, Mechanics, Nuclear

ArcelorMittal, Unimetal, Stein, NFM, Framatome, Alstom

Chemicals, Petrochemicals industry

Sanofi Aventis, Total, Du Pont De Nemours

Aeronautical industry

Aérospatiale, Airbus, Snecma, Eurocopter, Air France, Aéroport de Paris, Dassault Aviation



Agri-food industry

Nestlé, Danone, Bel, Palamatic, Tetrapak, Lactalis

Automobile industry

Renault, Peugeot, Citroën, Scania, Ford, RVI, Volkswagen, Michelin, Massey Ferguson, Manitou, Toyota Industrial Equipment

Other sectors

EDF, SNCF, RATP, Spie, Degremont, Eiffage, Polysius, Baudin Chateauneuf

 **VERLINDE**[®]
LIFTING EQUIPMENT

NEXT LEVEL
PARTNERSHIP

2, boulevard de l'Industrie | B.P. 20059 | 28509 Vernouillet cedex | France
Phone : (33) 02 37 38 95 95 | Fax : (33) 02 37 38 95 99 | Internet : www.verlinde.com

